

Spring Return acting actuator assembly codes

A

STANDARD

MOUNTING: IN LINE / FAIL TO CLOSE

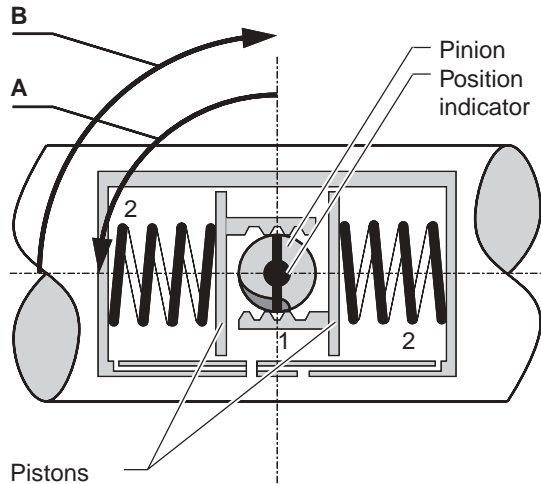

- A = Pilot valve operated** in Function Module - Central air chamber (1) pressurized
- B = Pilot valve not operated** in Function Module - Springstroke 2

All views are from above
Pistons are shown in inner position

B

MOUNTING: ACROSS LINE / FAIL TO CLOSE

- Position Indicator turned 90° (from standard)

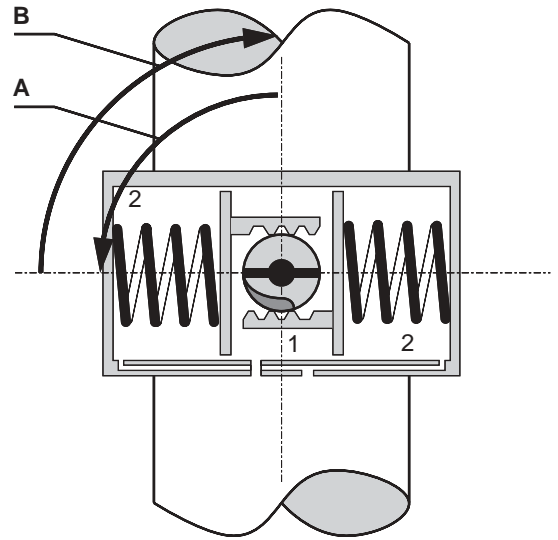

C

MOUNTING: ACROSS LINE / FAIL TO OPEN

- Pistons turned 180° (from standard) +
- Pinion turned 90° (from standard)

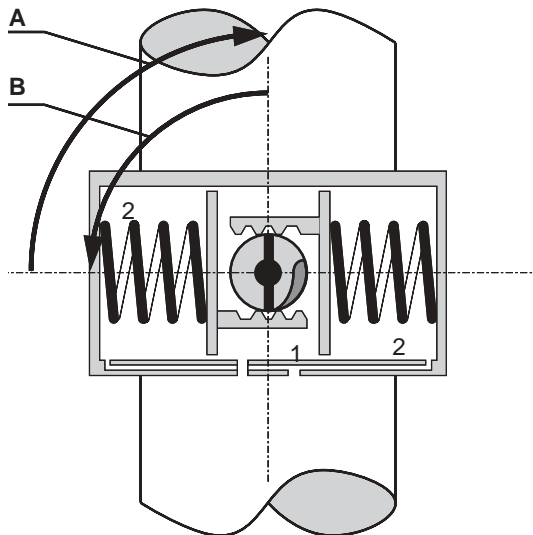

D

MOUNTING: IN LINE / FAIL TO OPEN

- Position Indicator turned 90° (from standard) +
- Pistons turned 180° (from standard) +
- Pinion turned 90° (from standard)

