



- Microprocessor controlled
- Password protected
- Analogue outputs
- RS 232 interface
- Peak memory
- Up to four floating limit value relays
- High-contrast LED display
- Back-lit LCD display for programming
- Standard temperature ranges: -30 to +50 to 0 to +400°C
- Temperature ranges re-scaleable on site

KOBOLD offices exist in the following countries:

ARGENTINA, AUSTRIA, BELGIUM, CANADA, CHINA,
FRANCE, GERMANY, GREAT BRITAIN, NETHERLANDS,
POLAND, SINGAPORE, SWITZERLAND, USA, VENEZUELA

KOBOLD Messring GmbH
Nordring 22-24
D-65719 Hofheim/Ts.
☎ (06192) 299-0
Fax (06192) 23398
E-mail: info.de@kobold.com
Internet: www.kobold.com

Model:
DTM



Description

Digital thermometers with intelligent electronics serve to display, monitor, control and transmit temperatures in production processes and equipment.

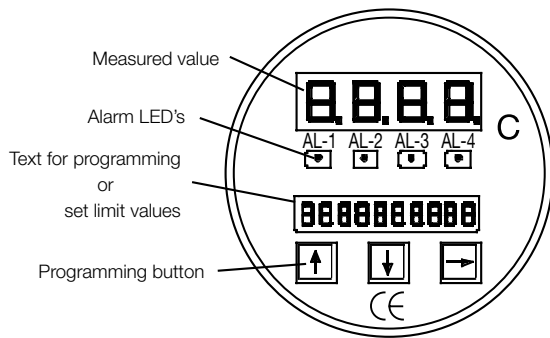

The new device series DTM... is remarkable for its ease operation and adaptation to the most demanding measurement applications.

A 4-segment 14 mm LED display provides clearly visible indication, the device is programmed with three arrow keys on the lower back-lit LCD display. The devices are fitted with an analogue output as standard. Other interfaces are available as options. Up to four limit values can be adjusted on the relay version.

The temperature to be measured is sensed by a platinum resistance thermistor and converted by the electronics to an analogue signal proportional to the temperature. The digital thermometer can be delivered in a compact shaft version for a maximum indicating range of a 200°C. Above 200°C the temperature detector should be connected externally to the basic device a cable.

Areas of Application

- Chemical industry, pharmaceutical industry, food
- Mechanical engineering and heavy industry
- Piping and vessel construction

Order Key

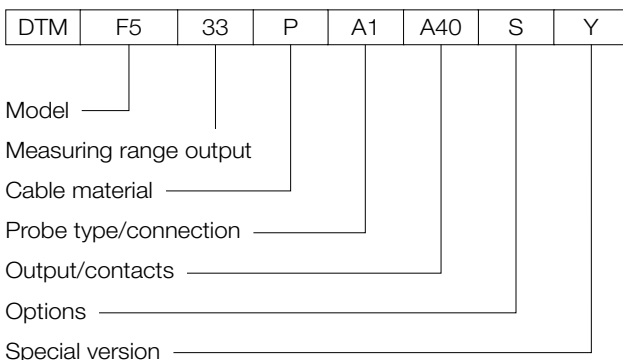

Please specify probe length and cable length (for distant-reading thermometers) in writing

Technical Details

- Casing: diameter 100 mm
material stainless steel, rear made of polyamide, front made of PAVG30 and polyester foil
- Electrical Connection: terminal blocks, PG 9 cable gland
- Protection: IP 65 according to DIN 40 050, IEC 529
- Probe: diameter 8 mm (others upon request)
material stainless steel 1.4571
- Probe length: according to customer specification, min. 50 mm
- Process connection: stainless steel 1.4571
- Indicating range: -30 to +50 to 0 to 400°C
- Accuracy class: 0.5
- Analogue output: 0-20 mA, 4-20 mA, 0-10 V (3-wire)
- Max. load/burden: ≤ 500 Ω for current output
≥ 500 Ω for voltage output
- Accuracy: typically < ±0.3% (limit point setting according to DIN 16 086)
- Repeatability: ≤ ±0.1%
- Limit value relay: Switch points adjustable
Switching hysteresis adjustable
Switch delay adjustable from 0.01 to 99.99 s
Max. switching voltage: 250 VAC, 220 VDC
Max. switching current: 3 A
Max. breaking capacity: 50 VA, 60 W
- Response time: Display and output signal < 100 ms
Relay output < 30 ms
- Supply: 15 to 30 VDC
- Service environment: Ambient temperature: -20 to +60°C
Storage temperature: -40 to +70°C

Functions (standard):

- Output signal
Setting of scaling and delay
- Display
Setting of scaling, decimal point and delay

Functions (optional):

- Peak memory with effect on display, output, relay
Internal reset with adjustable timer, keypad or RS 232
- serial interface RS 232

Stem thermometers (max. 200°C)

	Model: DTM-S0...
	Model: DTM-SA... DTM-SB... DTM-SC... DTM-SD...

Remote thermometers (max. 400°C)

	Model: DTM-F0...
	Model: DTM-F5...

Indicating ranges (analogue output)

°C	°C	°C
..24..= -20 to +40	..80..= 0 to +80	..30..= 0 to +300
..26..= -20 to +60	..10..= 0 to +100	..40..= 0 to +400
..35..= -30 to +50	..12..= 0 to +120	..YY..= special
..44..= -30 to +40	..16..= 0 to +160	
..46..= -30 to +60	..20..= 0 to +200	
..60..= 0 to +60		

Cable material (for remote thermometers only)

- ..0..= without (for stem thermometers)
- ..P..= PVC (max. 90°C) (please specify length in writing)

Standard probe/material/connection (probe diameter 8 mm)

	Description	Material	Thread	Order code
	Smooth probe	Stainless steel	without	..A0..
	Union nut	Stainless steel	G 1/2 G 3/4 G 1	..B1.. ..B2.. ..B3..
	Rotatable nipple for DIN sleeve	Stainless steel	G 1/2 G 3/4 G 1	..41.. ..42.. ..43..
	Union nut and shoulder nipple	Stainless steel	G 1/2 G 3/4 G 1 1/2" NPT 3/4" NPT 1" NPT	..11.. ..12.. ..13.. ..1A.. ..1B.. ..1C..

Please specify probe length in writing (min. 50 mm, standard 100 mm). Other threads upon request.

Outputs/limit contacts (order code)

Standard 4–20 mA – output without limit contacts

Analogue output	Limit contacts		
	without	2 contacts	4 contacts
4-20 mA	..A40..	..A4G..	..A4M..
0-20 mA	..A00..	..A0G..	..A0M..
0-10 V	..AV0..	..AVG..	..AVM..

Options

- ..S= peak memory
- ..R= RS 232 serial interface
- ..K= peak memory and RS 232

Dimensions

