

# Installation and Operation

## Pneumatic Positioner F10

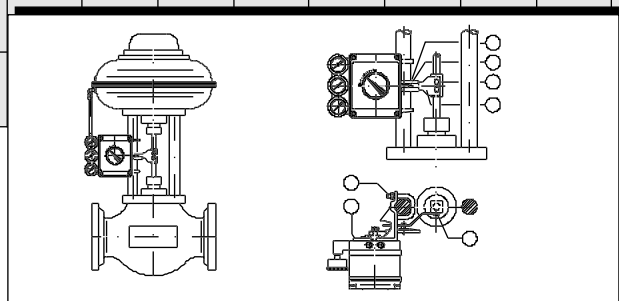
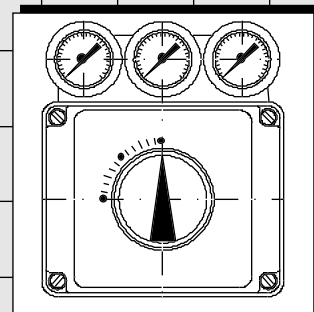
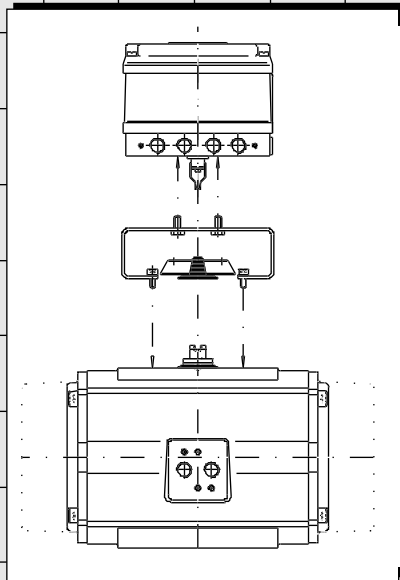
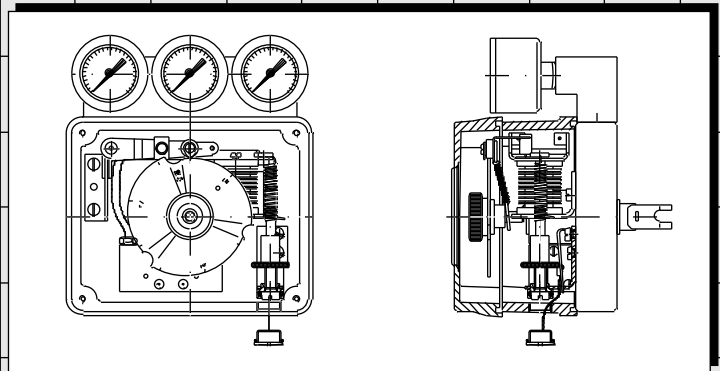
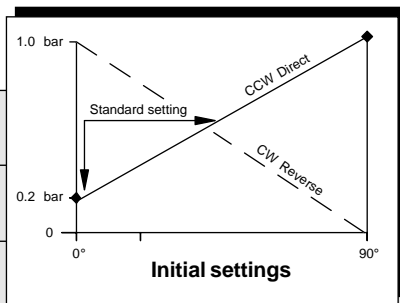

# F 10 Pneumatic Positioner

---

## Where to Find Information

	Page
Product Description	1
Operating Principle	2
Installation, Rotary Actuators	
- Mechanical	3
- Pneumatic, Double Acting	3
- Pneumatic, Single Acting	4
- Air Supply Requirement	4
Installation, Linear Actuators	
- Mechanical installation	5
- Pneumatic installation	6
Calibration	
- Initial Settings	7
- Cam Changes	7
- Zero Adjustment	8
- Range Adjustment	8
Trouble Shooting	9

## General Specification:

	<u>Metric</u>	<u>Imperial</u>
Hysteresis	: 0.6%	
Linearity	: 1.0%	
Air Flow	: 210 NI/min (at 6 bar)	: (7.4 SCFM at 87 psi)
Air Consumption	: 15 NI/min (at 6 bar)	: (0.6 SCFM at 87 psi)
Min. volume actuator	: 0.1 NI	: 6.1 in <sup>3</sup>
Temperature	: -20° to +80° C	: (-4° to +176°F)
Enclosure	: IP54 (option IP65)	: NEMA 3 (option NEMA 4)
Mounting	: VDI/VDE 3845 or IEC 534/6	
Air Entry	: G 1/4"	: (1/4" NPT)
Air Supply	: 1.4 to 8.6 bar	: (21 to 125 psi).
Input Signal		
- Standard	: 0.2 to 1.0 bar	: (3 to 15 psi).
- Adjustable	: 0.2 to 0.6 bar	: (3 to 9 psi).
	: 0.6 to 1.0 bar	: (9 to 15 psi).

**Media** : Non-lubricated instrument air, filtered at 25 micron.  
: Dew point should be 10°C (18°F) below environmental temperatur.  
: Air quality class 3-2-3 accord. to ISO 8573-1.

---

The F10 positioner provides the means for a pneumatic actuator to be positioned to any point between full open and full closed position. This allows accurate setting of rotary and linear control valves as well as a wide range of dampers and similar devices. The actuator's movement is controlled in proportion to a 0.2 to 1 bar (3-15 psi) incoming pressure signal.

The Posiflex F10 positioner provides:

- **A single model** covers both single acting and double acting actuators.
- **External Zero Adjustment.**
- **High accuracy** due to "high gain" amplification.
- **Four Position Cam for Linear Actuators** provides for linear, quick opening, equal percentage and split range characteristics.

- **Three Position Cam for Rotary Actuators** provides for linear, quick opening and equal percentage characteristics. A special cam for rotary actuator provides for split range.

- **Direct or Reverse Acting.**

F 10 positioners are available for both rotary and linear applications and because of the standardized mounting interface (VDI/VDE 3845 or IEC 534/6), installation is simple and trouble free. Mounting kits are available for most actuator types.

The purely Pneumatic mode of operation means that F10 positioners may be used in explosion hazardous areas without any additional protection being necessary.

A wide range of modular control options are available: These cover the addition of gauges, indicating switches, position transmitters, etc.

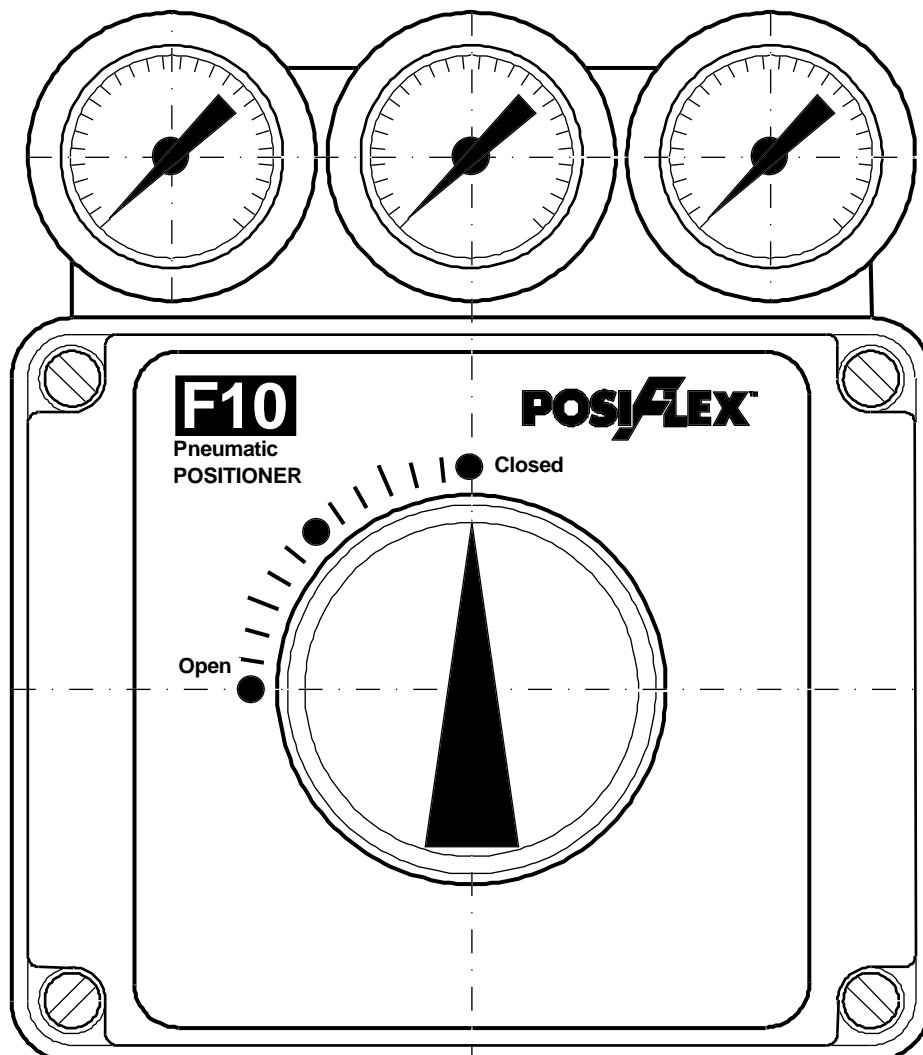

# Operating Principles

The Posiflex F10 Pneumatic Positioner is a high gain, motion balance instrument, suitable for use with a wide variety of single acting and double acting rotary and linear actuators.

Referring to the diagram below: The positioner is shown in a mid position with INSTRUMENT and SUPPLY air connected. The flapper and nozzle (5) maintains the instrument in its "balanced" state with just enough pilot air pressure being applied to the spool valve for it to hold the actuator in its "set" position.

When the actuator is required to move to a new "more open" position, the INSTRUMENT pressure is increased accordingly. This closes the air gap at the nozzle (5) causing an amplified pressure

increase at the spool valve end, this in turn displaces the spool and allowing an increasing air pressure at the "open" side of the actuator and exhausting air from the "close" side.

When the actuator moves position it rotates the cam (6) in a CCW (counter clockwise) direction and in doing so it progressively opens the air gap at the nozzle (5). On reaching the new set point the pilot pressure is reduced to the "balanced" state and again locks the actuator in new set position.

Similarly a decreasing INSTRUMENT pressure will cause a CW (clockwise) positioner movement.

The operation for single acting actuators is the same except that the unused pneumatic connection OUTPUT 2 is plugged off.

1. Balance assembly.
2. Pneumatic valve block.
3. Actuator.
4. Mechanical feedback.
5. Flapper and nozzle.
6. Cam.

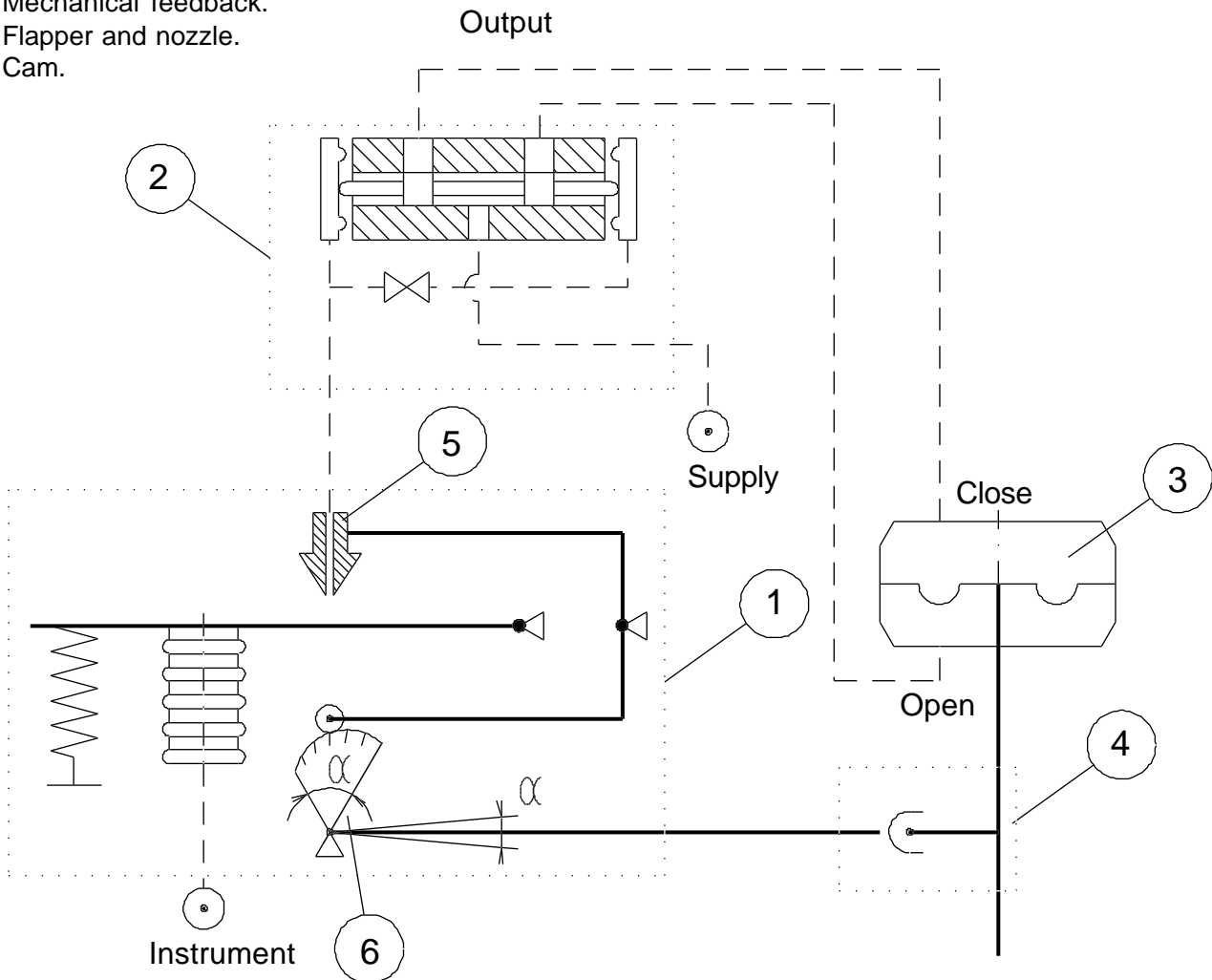

## Mechanical installation - Rotary actuators

The positioner is mounted on to the top surface of the pneumatic actuator using an appropriate mounting kit.

The positioner's mounting configuration is to the VDE/ VDI 3845 standard, if the actuator is to the same standard, a standard NAMUR mounting kit can be used, otherwise a special mounting kit will have to be obtained.

Assuming the installation will use the standard NAMUR mounting kit, proceed as follows:

1. Fix the bracket to the top surface of the actuator using the 4 screws provided.
2. Check that the spring clip is securely in place on the bottom of the positioner shaft.
3. Locate the positioner in place on top of the bracket, making sure that the 4 mm. tongue locates properly into it's slot in the actuator spindle and the centring screw is in position.
4. Fix the positioner to the bracket using the 4 screws provided.

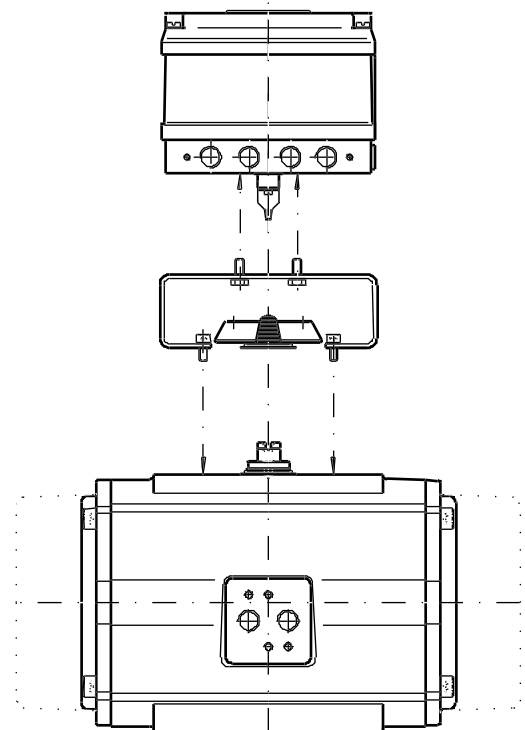

**Mechanical Installation**

## Pneumatic Connections - Double acting

This assumes a standard (direct acting) installation with an increasing signal to open the valve in a CCW (counter clockwise) direction.

***Before connecting any air supply make sure that the air available is clean dry instrument air filtered to at least 25 microns - see page 4.***

1. Connect an appropriate piece of air tubing between the port 1. on the positioner to the "A" port on the actuator. (The "A" port is the one that when air is applied to it, rotates the actuator in a counter clockwise direction).
2. Connect an appropriate piece of air tubing between the port 2. on the positioner to the "B" port on the actuator. (The "B" port is the one that when air is applied to it, rotates the actuator in a clockwise direction).
3. Connect an air supply to the positioner port Marked "Supply".
4. If the positioner is required to meet enclosure rating IP54, be sure that the "Exhaust" port is connected with elements which prevent the input of water and give no pressure rising inside the housing because of throttling of exhaust flow (no sintered filters, but a piece of tube or a special IP65 Exhaust plug with diaphragm

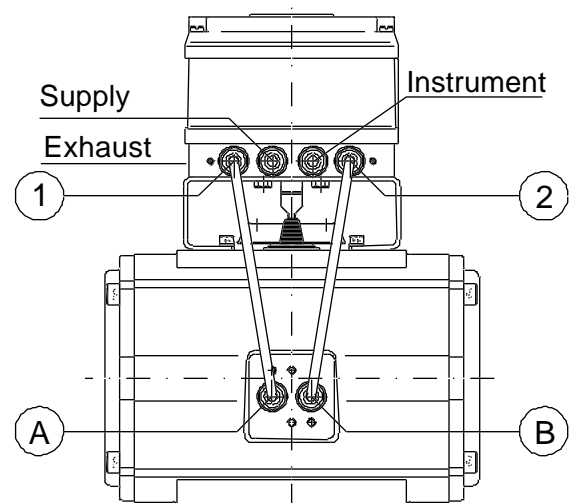

**Pneumatic connections  
Double acting**

5. Connect the instrument air to the port marked "INSTR".

**Note:** For a reverse acting assembly, both the air connections and the cam plate must be reversed - see page 7.

# Installation Rotary Actuators

## Pneumatic Connections - Single acting

This assumes a standard installation, direct acting with an increasing signal to open the valve in a CCW (counterclockwise) direction.

**Before connecting any air supply make sure that the air available is clean dry instrument air filtered to at least 25 microns - see below.**

1. Connect an appropriate piece of air tubing between the port 1. on the positioner to the "A" port on the actuator. (The "A" port is the one that, when air is applied to it, rotates the actuator in a counter clockwise direction).
2. Connect an air supply to the positioner port marked "Supply".
3. The unused positioner port 2, should be plugged using the pipe plug supplied with your positioner.  
Connect port "Exhaust" with elements, which guarantee IP54.
4. If the positioner is required to meet enclosure rating IP54, be sure that the "Exhaust" port is connected with elements which prevent the input of water and give no pressure rising inside the housing because of throttling of exhaust flow (no sintered filters, but a piece of tube or a special IP65 Exhaust plug with diaphragm).
5. Connect the instrument air to the port marked "INSTR".

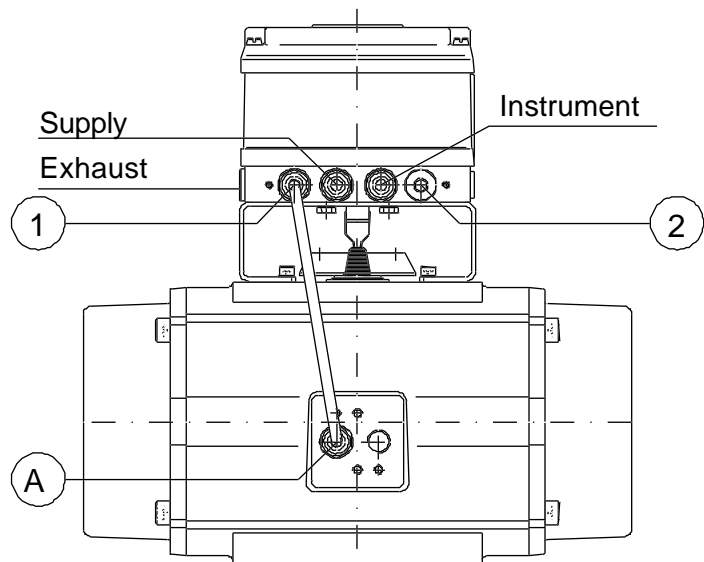

**Pneumatic Connections  
Single acting**

**Note:** For a reverse acting assembly, use the same procedure but remember that a reverse acting actuator must be used - see page 7.

## Air Supply Requirements

**CAUTION:** Pressure in excess of 8.6 bar (125 psi) will cause damage to the Positioner. Positioner supply air must be clean, dry and oil free.

The air should be filtered to at least 25 microns (as defined in the Instrument Society of America standard ISA S7.3 specifications). The filter should be installed as close to the positioner as possible to ensure maximum efficiency.

## Mechanical Installation - Linear Actuators

The mountings for linear positioners will vary dependent on the type of control valve.

The simplest assembly is where the control valve yoke is to the standard IEC 534-6 and has type "C" (Pillar) yoke design. A standard mounting kit is available for this and will provide a suitable mounting for most valves in this category.

Typical installation for a direct acting assembly. (Increasing signal opens the valve with a rising spindle).

1. Fix the bracket (1) to the positioner base, using the four bolts provided.
2. Move the valve spindle into a mid-stroke position.
3. Fix the lever (2) to the valve connection block (3) using the two M6 bolts. The carrier bolt (5) should be positioned loosely in the lever (2).
4. Assemble the slider on the feed back lever (7). Use assembly "a" (below) for strokes 60 to 100 mm. or assembly "b" for strokes 10 to 40 mm.
5. Locate the positioner, together with the bracket (1) on the left-hand pillar using the "U"-bolt clamps (4). (Use the right-hand pillar for reversacting assemblies). pass the carrier bolt (5) through the feedback lever slot, taking care to keep the anti-backlash spring (6) in it's correct position.
6. Slide the positioner up or down the pillar until the lever (2) and the feedback lever (7) are parallel. Fix in position.
7. Adjust the linkage to the correct stroke by moving the slider until the appropriate position on the feedback lever is indicated. Then tighten the carrier bolt (5).
8. Let the actuator make a full stroke and check that the linkage moves freely within the bracket.
9. Move the actuator to it's "zero" position. Turn the positioner shaft counterclockwise (CCW) to the end of stroke. Fasten the feedback lever to the positioner shaft.

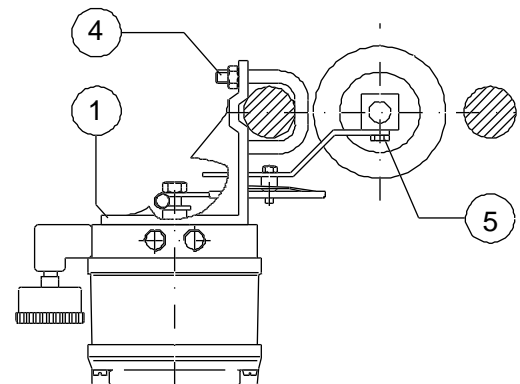
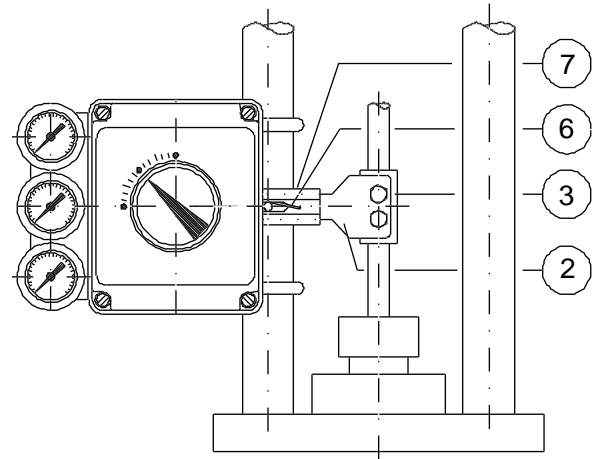

**Linear mounting**

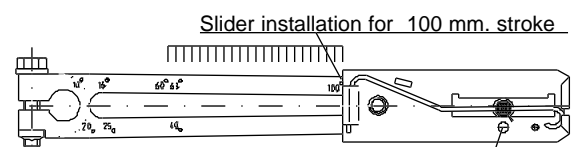

Installation mark for 60 and 100 mm. stroke  
a) Lever for 60 to 100 mm. Stroke

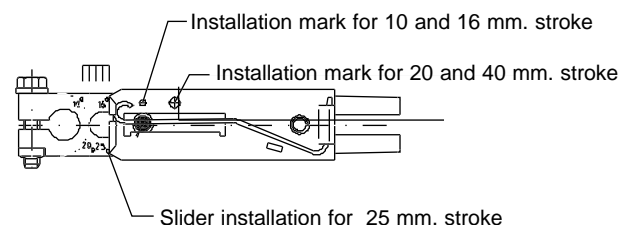

Installation mark for 10 and 16 mm. stroke  
Installation mark for 20 and 40 mm. stroke  
Slider installation for 25 mm. stroke  
b) Lever for 10 to 40 mm. Stroke

# Installation - Linear Actuators

---

## Pneumatic Connections - Double acting

Assuming a standard installation, direct acting with an increasing signal to open the valve (rising spindle).

**Before connecting any air supply make sure that the air available is clean dry instrument air filtered to at least 25 microns.**

1. Connect an appropriate piece of air tubing between the port 1. on the positioner to the "A" port on the actuator. (The "A" port is the one that, when air is applied to it, opens the valve).
2. Connect an appropriate piece of air tubing between the port 2. on the positioner to the "B" port on the actuator. (The "B" port is the one that when air is applied to it, closes the valve).
3. Connect an air supply to the positioner port marked "S".
4. If the positioner is required to meet enclosure rating IP54, be sure that the "Exhaust" port is connected with elements which prevent the input of water and give no pressure rising inside the housing because of throttling of exhaust flow (no sintered filters, but a piece of tube or a special IP65 Exhaust plug with diaphragm
5. Connect port "Instrument" with pneumatic input signal.

**Note:** For a reverse acting assembly, both the air connections and the cam must be reversed - see page 7.

## Pneumatic Connections - Single acting

Assuming a standard installation, with direct acting an increasing signal to open the valve (rising spindle).

**Before connecting any air supply make sure that the air available is clean dry instrument air filtered to at least 25 microns.**

1. Connect an appropriate piece of air tubing between the port 1. on the positioner to the "A" port on the actuator. (The "A" port is the one that when air is applied to it, opens the valve).
2. Connect an air supply to the positioner port marked "S".
3. If the positioner is required to meet enclosure rating IP54, be sure that the "Exhaust" port is connected with elements which prevent the input of water and give no pressure rising inside the housing because of throttling of exhaust flow (no sintered filters, but a piece of tube or a special IP65 Exhaust plug with diaphragm

4. Connect port "Instrument" with pneumatic input signal.

**Note:** For a reverse acting assembly, both the air connections and the cam must be reversed - see page 7.

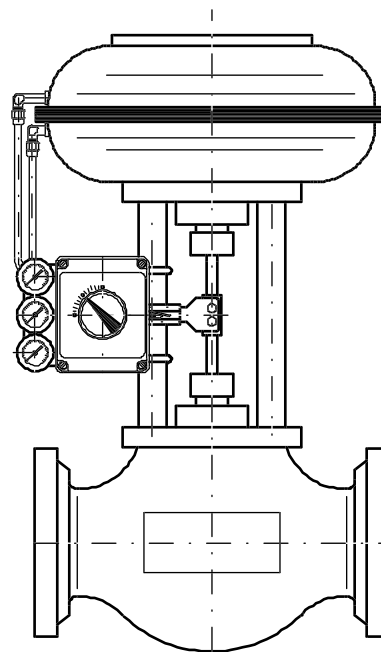

**Double acting**

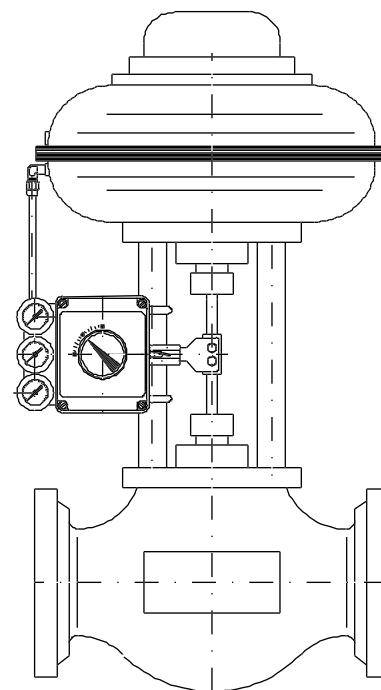

**Single acting**

# Calibration - Initial Settings - Cam Changes

## Initial Settings

The factory settings provide the positioner with an initial range of settings that will allow the operation of positioners on most applications.

- Signal Input - 0.2 to 1.0. bar. (3-15 psi).
- Range - 0% to 100%
- Control Function - Linear.
- Action - Direct Acting.  
(Opening on increasing Signal in CCW-direction).

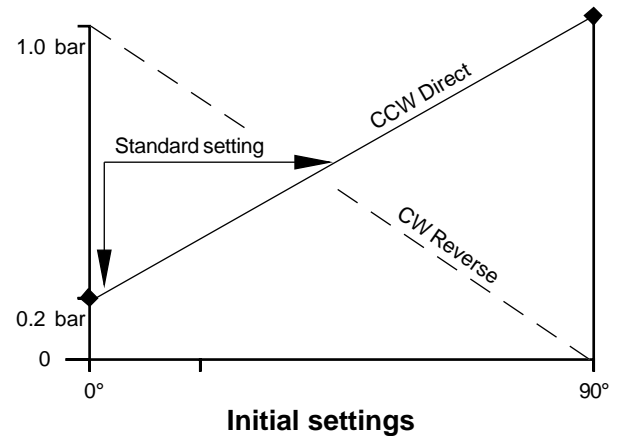

The F10 positioner is provided with the following features for making changes to the initial settings:

- Zero** By the external zero adjustment screw.
- Range** By the internal range adjustment ring.
- Range Spring** The standard range spring is suitable for normal operation and split ranging.
- Cam Segment** Six segments are provided for the rotary positioner and eight segments for the linear positioner (see table).

Cam Segment			
Rotary actuator		Linear actuator	
90° CCW	90° CW	40° CCW	40° CW
lin	lin	lin	lin
=%	=%	=%	=%
QO	QO	QO	QO
*	*	SR	SR

## Cam Changes

Remove the cover and indicator from the positioner exposing the Cam. The Cam is double sided: CCW for direct acting, CW for reverse acting.

- lin = linear
- =% = equal percentage
- QO = Quick Opening
- SR = Split Range
- \* = Special cam split range

If the actuator is fully clockwise and the actuator is to rotate CCW on instrument signal increase, the Cam should be on the "CCW" side and the start marking should be in line with the Cam Follower Bearing. If the actuator is fully counterclockwise and the actuator is to rotate CW on instrument signal increase, the Cam should be on the "CW" side and the start marking should be in line with the Cam Follower Bearing.

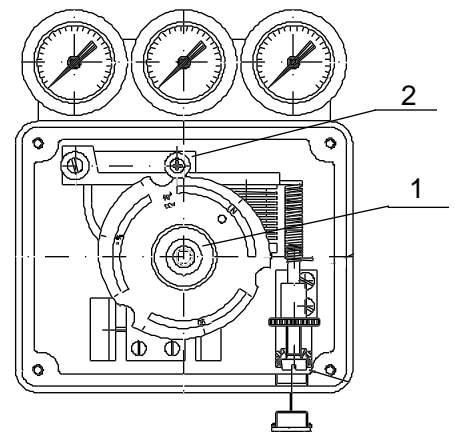

If the cam is not in the correct position, change as follows:

1. Remove the cam nut (1).
2. Re-install the cam plate in the correct position, taking care that the correct segment is adjacent to the cam follower (2).
3. Replace the cam nut and fix it.
4. Replace the indicator disk, taking care that it is in the correct position.

Top view of cam

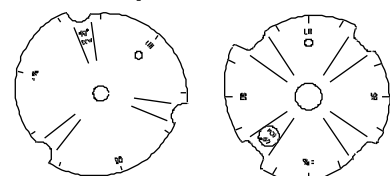

Rotary actuator Cam 90°      Linear actuator Cam 40° (49°)

# Calibration - Zero and Range

---

Before making any adjustments positioner should be properly mounted, the cam should be in the correct sector on the correct side as determined from the cam markings.

## Zero Adjustment

The zero adjustment is carried out externally, this is located at the right hand side of the positioner casing and is accessed by means of a removable plug.

1. Remove the access plug (1).
2. Adjust the instrument signal to its minimum value (0.2 bar for a 0.2-1.0 bar range), (3 psi for a 3-15 psi range).
3. Rotate the Zero adjusting screw (2) until the actuator just begins to move. Turning the adjusting nut clockwise raises the start value.
4. After adjustment, replace the access plug (1).

## Range Adjustment

Remove the cover from the positioner exposing the knurled range adjuster ring, this is located at the righthand side of the assembly.

The factory set range is so that a 0.2 to 1.0 bar (3-15 psi) instrument pressure produces a full stroke movement. This may be changed by resetting the full stroke position (max. opening) at the 1.0 bar (max. instrument) pressure. To adjust the range carry out the following:

1. Increase the instrument signal to its maximum value (1.0 bar for a 0.2 to 1.0 bar range), (15 psi for a 3-15 psi range).
2. If the actuator does not reach its final position, rotate the knurled adjusting ring (3) in CCW-direction until the full stroke position is reached.
3. Turning the range screw cw reduces the range; ccw increases the range.
4. After range adjustment, reset the zero position and adjust it if necessary.

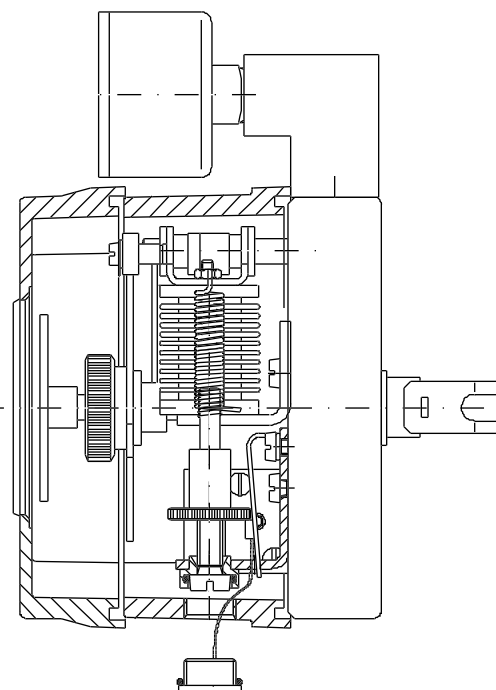
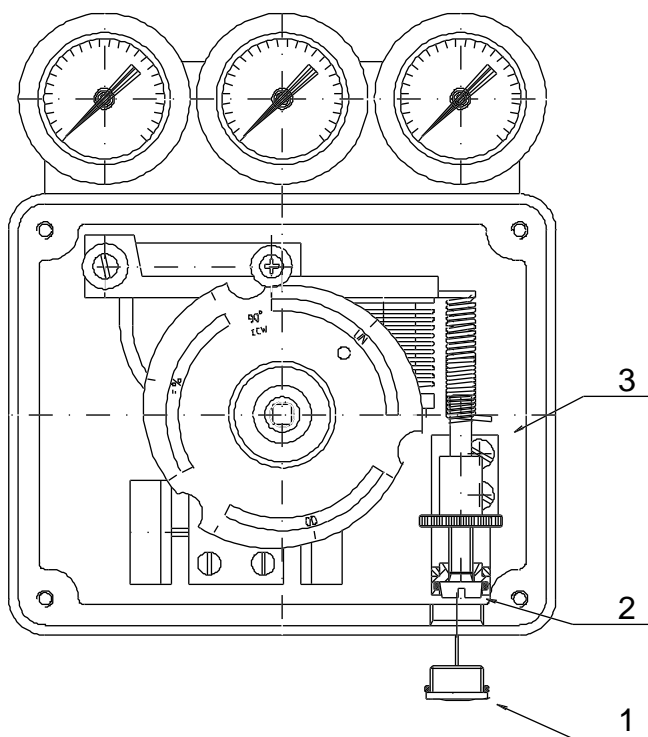

## **Troubleshooting**

If it is suspected that the positioner is not operating correctly, check the following :

1. Is the Cam in the proper orientation for your application ? (See page 5).
2. Is the positioner properly mounted ? (See page 3).
3. Is the coupling or NAMUR shaft in proper alignment with the Positioner Cam shaft and actuator ?
4. Is the positioner piped correctly ? (See page 3 and 4).
5. Make sure supply pressure exceeds minimum pressure required to move the actuator.
6. Is there instrument and output pressure at the Positioner ? (If the Positioner is equipped with a Gauge Block, check the instrument and output pressure readings. If the positioner is not equipped with a Gauge Block, connect gauges to the instrument and output ports and note readings.)
7. Is the actuator working properly ? (Disconnect the supply pressure from the Positioner and connect the supply pressure to the actuator. Does the actuator move full stroke ?)

If additional help is needed, contact your local El-o-matic office or representative, (see back page).

**INTERNATIONAL**

EL-O-MATIC B.V.  
P.O. Box 223  
7550 AE Hengelo (O)  
Asveldweg 19  
7556 BR Hengelo (O)  
Holland  
Tel. +31 74 256 10 10  
Fax. +31 74 291 09 38

**FRANCE**

EL-O-MATIC France  
Z.A. Créapole 1  
32 Rue de Tournenfiles  
91540 Mennecy  
Tel. +33 1 69 900 734  
Fax. +33 1 69 900 709

**VENEZUELA**

EL-O-MATIC INTERNATIONAL  
Av. Principal Los Ruices  
Edif. stemo piso 1 Ofc. 1A  
Caracas  
Venezuela  
Tel. +58 2 237 77 51  
Fax. +58 2 238 9023

**SOUTH AFRICA**

EL-O-MATIC (Pty) Ltd.  
Teknipark, 62 Lower Germiston Road  
Heriotdale, Johannesburg  
P.O. Box 40348  
Cleveland 2022  
Tel. +27 11 626 2880/1/2  
Fax. +27 11 626 2905

**BENELUX**

EL-O-MATIC Benelux  
P.O. Box 223  
7550 AE Hengelo (O)  
Asveldweg 11  
7556 BT Hengelo (O)  
Holland  
Tel. +31 74 256 10 20  
Fax. +31 74 243 86 90

**GERMANY**

EL-O-MATIC GmbH.  
Postfach 460234 . 47856 Willich  
Siemensring 112 . 47877 Willich  
Tel. +49 2154 499660  
Fax. +49 2154 427669

**INDIA**

EL-O-MATIC India Pvt Ltd.  
296/A/1/5, St. Patrick's Town  
Near Railway Crossing  
Hadapsar Industrial Estate  
Pune 411 013  
Tel. +91 212 672916  
Fax. +91 212 674465

**AUSTRALIA / NEW ZEALAND**

EL-O-MATIC Austral-Asia  
329 Brighton Road, Brighton 5048  
P.O. Box 12  
Glenelg 5045  
South Australia  
Tel. +61 8 377 2744  
Fax. +61 8 377 2576

**UNITED KINGDOM**

EL-O-MATIC Ltd.  
16/17 Beeding Close  
Southern Cross Trading Estate  
Bognor Regis  
West Sussex, PO 22 9TS  
Tel. +44 1243 830 363  
Fax. +44 1243 830 843

**U.S.A.**

EL-O-MATIC U.S.A. Inc.  
135 English Street  
Hackensack NJ 07601  
Tel. +1 201 489 5550  
Fax. +1 201 489 9171

**SINGAPORE**

EL-O-MATIC Valve Actuators  
Far East Pte Ltd.  
28 Third Lok Yang Road  
Singapore 628016  
Tel. +65 26 24 515  
Fax. +65 2680028 / 770 80 80